



DBK43A™

8-Channel Strain Gage Module



Compatibility: ✓ LogBook ✓ DaqBook ✓ DaqLab ✓ DaqScan ✓ DaqBoard/2000 Series

Features

- Provides eight channels of strain gage input
- Accommodates most bridge-type sensors, including 4-element full and 3-wire quarter bridges
- Individual excitation regulator per channel
- User-selected low-pass filter

The DBK43A™ eight-channel strain gage expansion module for IOtech's data acquisition systems accommodates the connection of most strain gage types, from single-element, 3-wire quarter bridges to 4-element full bridges. The DBK43A also includes provisions for bridge completion resistors and provides four externally accessible adjustments on each of its eight channels, including excitation voltage, input gain, offset nulling, and output scaling. Up to 32 DBK43A modules can be connected to one system for up to 256 strain gage channels.

The DBK43A includes a built-in DC/DC converter, allowing the unit to be operated from an external power source while drawing very little power from the data acquisition system. The external power source can be the included AC adapter, the DBK30A rechargeable battery/excitation module, a car battery, or any 9 to 18 VDC source.

The DC/DC converter also provides excitation voltages for all channels. Each of its eight on-board excitation regulators can be externally adjusted from 1.5 to 10.5 VDC. The regulator outputs have remote sensing terminals and feature 50 mA current limiting to prevent damage from short-circuits or overloads. The wide regulator voltage range allows virtually any resistive or semi-conductive gage type to be incorporated into a system.

Input Amplifier. The DBK43A's input amplifiers provide an input gain range of x100 to 1250. Because input signals can vary widely in range, the DBK43A's extensive range is a superior alternative to fixed-gain or slot-range amplifiers.



The DBK43A provides eight channels of strain gage input

DBK43A's Typical Bridge Configuration (for one of 8 channels)

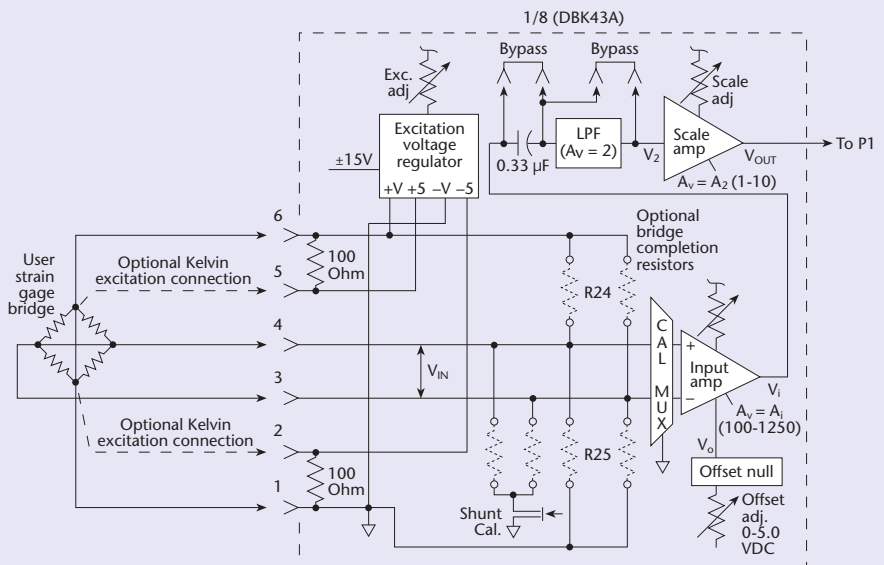

Offset and Scaling Gain. The DBK43A's 0 to 5 VDC offset adjustment range and output-gain scaling permit nulling of large quiescent loads and expansion of dynamic range for maximum resolution. This is an important feature because strain gages typically exhibit pre-load or quiescent output, leading to a non-zero output prior to the application of the load to be measured. The DBK43A's offset adjustments are used to null these pre-load conditions.

The remaining signal can then be expanded by the DBK43A's output scaling amplifiers to increase the resolution.

Shunt-Calibration Feature. The DBK43A offers locations in each channel amplifier for user-supplied shunt calibration resistors. This feature allows you to simulate, under software control, a pre-set bridge disturbance to aid in calibration and verification of each channel setting.



DBK43A™

Specifications & Ordering Information

Software

The DBK43A includes GageCal™, a program that enables you to easily configure, calibrate, and set up your strain gage application. The program features an intuitive graphical user interface (GUI) that guides you through the configuration of the DBK43A and its adjustment to the applied strain gage bridge.

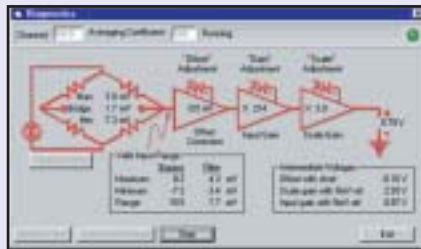

The DBK43A can be easily configured via its Windows software



The DBK43A's software supports three calibration methods: nameplate, 2-point, and shunt

Coupling and Filtering. Each DBK43A channel features a user-selectable AC or DC coupling between the input amplifier circuits, and a selectable 3-pole, low-pass filter with user customizable cut-off frequency. Elective capacitive coupling, which is selected via user-installable jumpers, allows separation of dynamic signals from static deflection levels.

Bridge-Completion Resistors. Physical locations are provided for up to four bridge-completion resistors per channel, allowing you to accommodate virtually any type of external configuration without having to attach bridge completion resistors to the strain gage.

Specifications

Connector: DB37 male, mates with P1*; mini-DIN6 provided for each strain gage and external excitation connection

Number of Channels: 8

Excitation Voltage Adjustment Range: 1.50 to 10.50 VDC @ 50 mA

Input Gain Range: x100 to 1250; separate instrumentation amplifier for each channel with gain adjustable via externally accessible 15-turn trimpot

Accommodated Bridge Types

- Full bridge, Kelvin excitation (6-wire)
- Full bridge (4-wire)
- Half bridge (3-wire)
- Quarter bridge (2-wire and 3-wire)

Bridge Resistors: On-board resistor locations are for four bridge-completion resistors per channel

Input Type: Differential

Input Impedance: 100M Ohm parallel with 100 pF

CMRR: 115 dB (DC to 60 Hz)

Input Power Source:

Included AC supply, or user supplied +9 to +18 VDC @ 600 mA max

Excitation Current Output: 50 mA max (current limited @ 60 mA)

Excitation Sensing: Local or remote

Excitation Regulation:

Line Regulation: 0.025%

Load Regulation: 0.5%

Reference Voltages: 2.5 VDC

Reference Accuracy: 0.15%

Reference Drift: 25 ppm/C° max

Gain Calibration Reference: 5.00 mVDC

Reference Accuracy: 0.2%

Input Offset: 200 µV max

Offset Drift: 4 µV/C°

Output Offset: 4 mV

Offset Drift: 6 µV/C°

Offset Adjustment: 0 to 100% of range, 0 to 5.00 VDC (15-turn trimpot)

Full-Scale Sensitivity Range:

At 5.00 VDC excitation: 0.8 to 10 mV/V

At 10.00 VDC excitation: 0.4 to 5 mV/V

Scaling Amplifier Gain Range: x1 to 10 (15-turn trimpot)

Low-Pass Filter: 3-pole, user selectable; corner frequency (Fc) set by user-supplied component; attenuation -3 dB at Fc; gain x2 (10 Hz installed)

Dimensions: 285 mm W x 221 mm D x 35 mm H (11" x 8.5" x 1.375")

Weight: 1.3 kg (3 lbs)

Ordering Information

Description	Part No.
8-channel strain gage module	DBK43A

Accessories

120 Ohm bridge-completion resistor	BCR/120/1
350 Ohm bridge-completion resistor	BCR/350/1
1000 Ohm bridge-completion resistor	BCR/1000/1
Rack mount kit	RackDBK2
Additional blank header	CN-115

Cables

Set of eight 6 ft. cables with mating mini-DIN 6 connector	CA-132
Shielded P1 T cable for use with DaqBook/2020, LogBook/360, and WBK40/41	CA-255-4T
Shielded P1 T cable for use with DaqBook/2001, DaqBook/2005, LogBook/300, DaqLab/2001, and DaqLab/2005	CA-255-2T
Ribbon cable for use with DaqScan	CA-37-x

Note: The CA-37-x ribbon cable can also be used in lieu of the CA-255-x molded T cables.

For complete information on accessories and cables, visit www.iotech.com/acc

Related Products

LogBook	p. 75
DaqBook	p. 89
DaqLab	p. 103
DaqScan	p. 108
DBK16	p. 130
DaqBoard/2000 Series	p. 192



CA-132, eight strain gage cables for DBK43A

* Attachment to the DaqBoard/2000 requires a DBK200, DBK201, DBK202, or DBK203 adapter